

CONTROL BOX

— 产品说明书/ User Manual —



EN

DE

FR

IT

ES

RU

NL

PT

PL

TR

HU

日本語

繁體中文

简体中文

EN WARNING

- Please read this user manual carefully before operation.
- Avoid strong vibration and dropping from heights.
- Do not disassemble, modify, or repair on your own.
- Prevent water or other liquids from entering the product to avoid damage.
- Avoid storing in damp, high-temperature, or oily environments.
- Use appropriate force when connecting and removing devices.
- Children should use this product under adult supervision.

DE WARNUNG

- Bitte lesen Sie dieses Handbuch sorgfältig durch, bevor Sie Ihr Spielerlebnis beginnen.
- Vermeiden Sie starke Vibrationen und Stürze aus großer Höhe.
- Zerlegen, modifizieren oder reparieren Sie das Produkt nicht selbst.
- Vermeiden Sie das Eindringen von Wasser oder anderen Flüssigkeiten, um Schäden zu vermeiden.
- Vermeiden Sie die Lagerung in feuchten, heißen oder öligen Umgebungen.
- Wenden Sie beim Anschließen und Entfernen von Geräten angemessene Kraft an.
- Kinder sollten dieses Produkt nur unter Aufsicht von Erwachsenen verwenden.

FR AVERTISSEMENT

- Veuillez lire attentivement ce manuel avant utilisation.
- Évitez les vibrations fortes et les chutes en hauteur.
- Ne démontez, ne modifiez et ne réparez pas l'appareil vous-même.
- Empêchez l'eau ou d'autres liquides de pénétrer dans le produit.
- Évitez de stocker le produit dans des environnements humides, à haute température ou gras.
- Appliquez une force appropriée lors de la connexion/déconnexion des périphériques.
- Les enfants doivent utiliser ce produit sous surveillance adulte.

IT AVVERTENZA

- Leggere attentamente il manuale prima dell'uso.
- Evitare vibrazioni forti e cadute da altezze.
- Non smontare, modificare o tentare riparazioni autonomamente.
- Evitare che acqua o altri liquidi penetrino nel prodotto per prevenire danni.
- Evitare di conservare il prodotto in ambienti umidi, ad alta temperatura o oleosi.
- Utilizzare una forza appropriata durante il collegamento e la rimozione dei dispositivi.
- I bambini devono utilizzare il prodotto sotto la supervisione di un adulto.

ES ADVERTENCIA

- Lea detenidamente este manual de usuario antes de utilizar el producto.
- Evite vibraciones fuertes y caídas desde alturas.
- No desensamble, modifique o repare el producto por su cuenta.
- Evite que agua u otros líquidos entren en el producto para prevenir daños.
- No lo almacene en ambientes húmedos, de alta temperatura o con presencia de grasa.
- Aplique fuerza adecuada al conectar o desconectar dispositivos.
- Los niños deben utilizar este producto bajo supervisión de un adulto.

RU ПРЕДУПРЕЖДЕНИЕ

- Перед началом эксплуатации внимательно прочтите данное руководство пользователя.
- Избегайте сильной вибрации и падения с высоты.
- Не разбирайте, не модифицируйте и не ремонтируйте самостоятельно.
- Не допускайте попадания воды или других жидкостей в изделие, чтобы избежать повреждений.
- Не храните во влажной, высокотемпературной или задымленной среде.
- Применяйте соответствующие усилия при подключении и отключении устройств.
- Дети должны использовать это изделие под присмотром взрослых.

NL WAARSCHUWING

- Lees deze gebruikershandleiding zorgvuldig door voor gebruik.
- Vermijd sterke trillingen en vallen van grote hoogtes.
- Demonteer, wijzig of repareer het product niet zelf.
- Voorkom dat er water of andere vloeistoffen in het product komen om schade te voorkomen.
- Vermijd opslag in vochtige, hoge-temperatuur- of vette omgevingen.
- Gebruik de juiste kracht bij het aansluiten en loskoppelen van apparaten.
- Kinderen dienen dit product onder toezicht van een volwassene te gebruiken.

PT OSTRZEŻENIA

- Leia o manual cuidadosamente antes de usar.
- Evite vibrações fortes e quedas.
- Não desmonte ou repare o produto por conta própria.
- Evite contato com líquidos.
- Armazene em local seco, longe de calor ou óleo.
- Use força adequada ao conectar/desconectar dispositivos.
- Crianças devem usar sob supervisão adulta.

TR UYARI

- Lütfen işleme geçmeden önce bu kullanım kılavuzunu dikkatlice okuyun.
- Şiddetli titreşim ve yüksekten düşürmeden kaçının.
- Kendi başınıza sökmeyin, değiştirmeyin veya tamir etmeyin.
- Ürünün su veya diğer sıvılarla temas etmesini önleyin, aksi takdirde hasar oluşabilir.
- Nemli, yüksek sıcaklıklı veya yağlı ortamlarda saklamaktan kaçının.
- Cihazları bağlarken ve çıkarırken uygun kuvvet kullanın.
- Çocuklar bu ürünü yetişkin gözetiminde kullanmalıdır.

繁體中文 警告

- 操作前請仔細閱讀說明書。
- 避免強烈振動及重力跌落。
- 請勿自行分拆、改裝及修理。
- 避免水或其他液體進入產品內部，以免造成損壞。
- 避免存放於潮濕、高溫、油煙等場所。
- 連接和移除設備時，注意用力適當。
- 兒童需在成年人的監護下使用本產品。

简体中文 警告

- 操作前请仔细阅读说明书。
- 避免强烈振动及重力跌落。
- 请勿自行分拆、改装及修理。
- 避免水或其它液体进入产品内部，以免造成损坏。
- 避免存放于潮湿、高温、油烟等场所。
- 连接和移除设备时，注意用力适当。
- 儿童需在成年人的监护下使用本产品。

PL OSTRZEŻENIE

- Przed rozpoczęciem użytkowania należy uważnie przeczytać instrukcję obsługi.
- Unikać silnych wibracji i upadków z wysokości.
- Nie demontować, modyfikować ani naprawiać samodzielnie.
- Zapobiegać przedostawaniu się wody lub innych płynów do produktu, aby uniknąć uszkodzenia.
- Unikać przechowywania w wilgotnych, wysokotemperaturowych lub oleistych środowiskach.
- Podczas podłączania i odłączania urządzeń należy używać odpowiedniej siły.
- Dzieci powinny korzystać z tego produktu pod nadzorem osoby dorosłej.

HU FIGYELMEZTETÉS

- A működtetés előtt kérjük, olvassa el figyelmesen ezt a felhasználói kézikönyvet.
- Kerülje az erős rázkódást és magasból való leejtést.
- Ne szerelje szét, módosítsa vagy javítsa saját maga.
- Megakadályoznia, hogy víz vagy más folyadék kerüljön a termékbe, hogy elkerülje a károsodást.
- Kerülje a nedves, magas hőmérsékletű vagy olajos környezetektől való tárolást.
- Használjon megfelelő erőt az eszközök csatlakoztatásakor és eltávolításakor.
- A gyermekek felnőtt felügyelete mellett használják ezt a terméket.

日本語 警告

- 本製品を操作する前に、本ユーザーマニュアルをよくお読みください。
- 強い振動や高所からの落下を避けてください。
- 自分で分解、改造、修理をしないでください。
- 製品の損傷を防ぐため、水やその他の液体が入らないようにしてください。
- 湿気が多い場所、高温の場所、または油分の多い環境での保管を避けてください。
- デバイスの接続や取り外しの際は、適切な力で行ってください。
- 子供が使用する場合は、必ず大人の監督のもとで使用してください。

   : PXNgame

 YouTube : PXN Official

 Discord : PXN

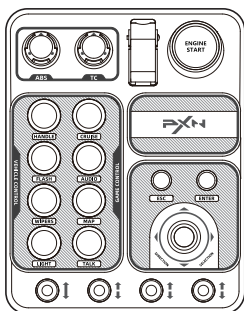

x1

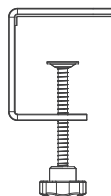

x1



x1



x1

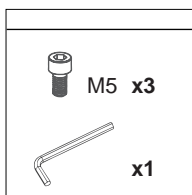

M5 x3

x1

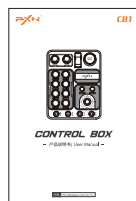

FOR

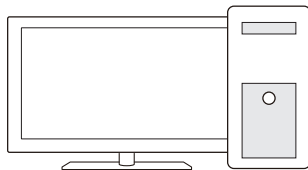

PC (Windows 7/ 8/ 10/ 11)

* The CB1 cannot be used directly after connecting to the PC; button functions must be manually bound within the game.

* CB1连接PC后不能直接使用，需要到游戏内手动绑定按键功能



1

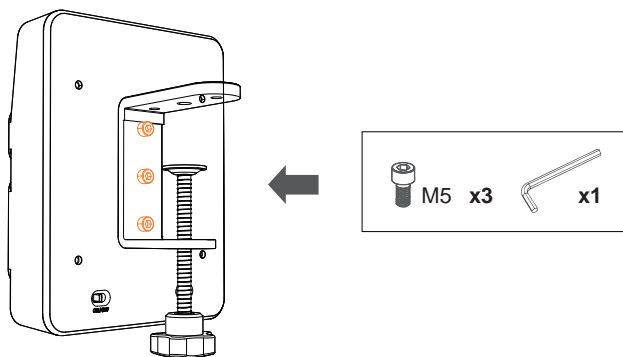

2

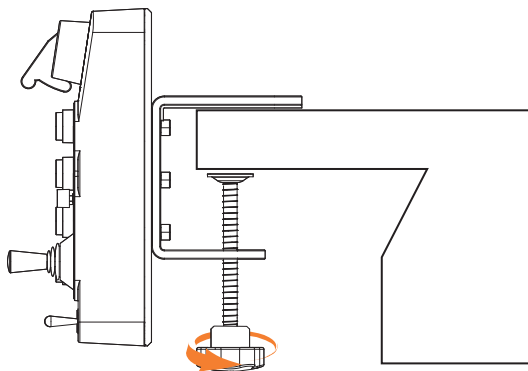

USE ON PC

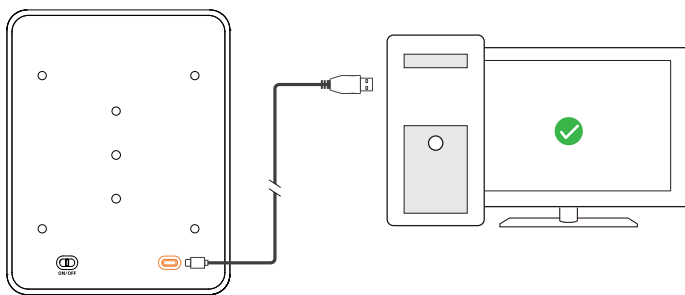

RGB POWER SWITCH RGB电源开关

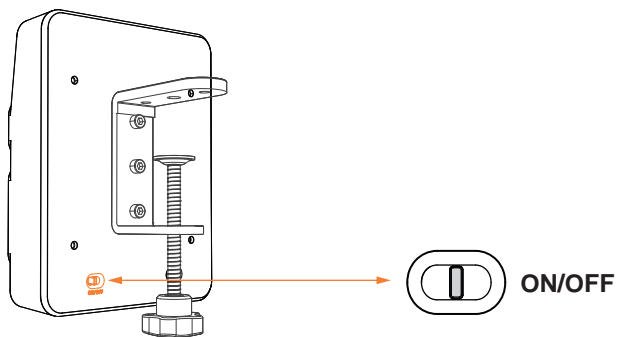



RGB COLOR CYCLE

RGB颜色切换

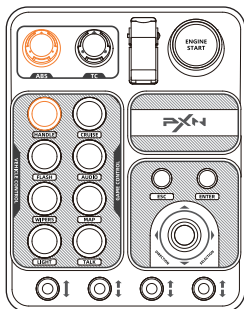

HANDLE



+

ABS

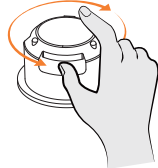

RGB BRIGHTNESS ADJUSTMENT

RGB亮度调节

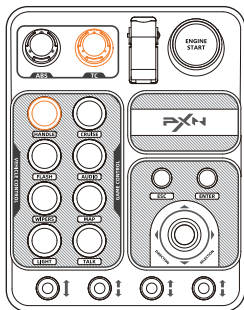

HANDLE



+

TC

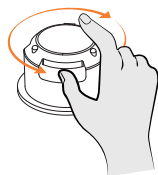

MAPPING BUTTON ON/ OFF

映射按键- 开/关

* The ESC and ENTER buttons are bound by default to their corresponding keyboard buttons.

* ESC 和 ENTER 默认绑定键盘对应名称按键

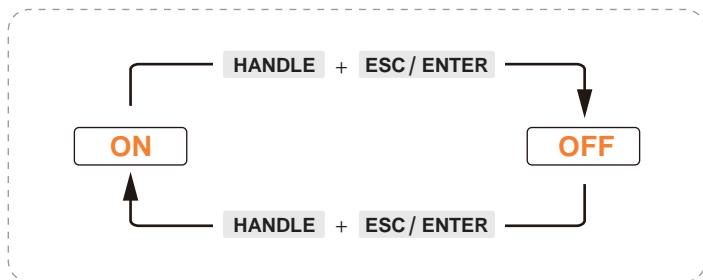
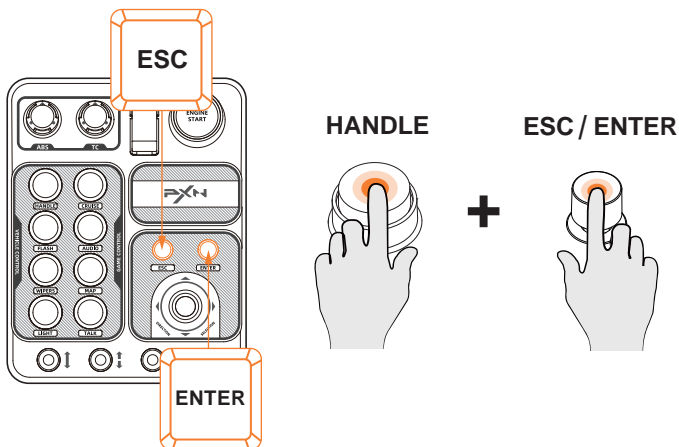



MEDIA CONTROL

多媒体功能

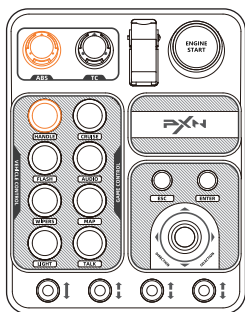

HANDLE



+

ABS

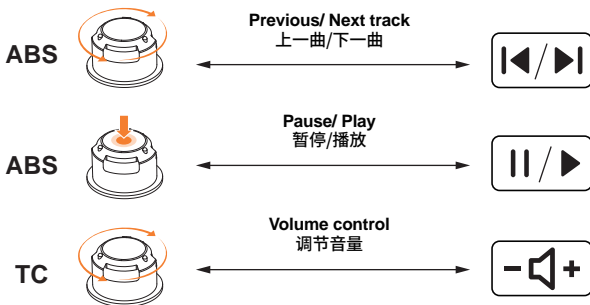
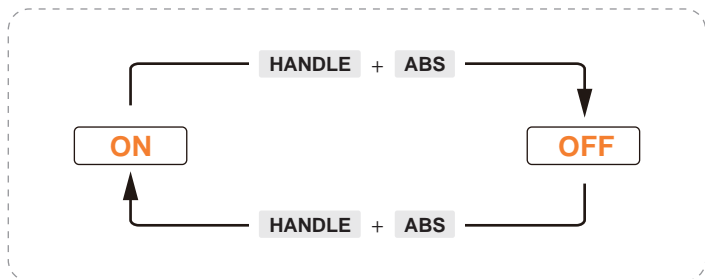
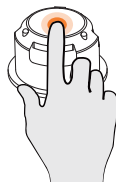

EN Product Specifications

Model: CB1	
Connection Method: Wired Connection	Operating Current: ≤300mA
Package Dimensions: About 231 * 241 * 120 mm	Power Supply: 5V
Product Dimensions: About 184 * 144 * 78.5 mm	Operating Temperature: 10-40°C
Product Weight: About 540 g	Operating Humidity: 20~80%

DE Produktspezifikationen

Modell: CB1	
Verbindungsmethode: Kabelverbindung	Arbeitsstrom: ≤300mA
Verpackungsmaße: Ca. 231 * 241 * 120 mm	Stromversorgung: 5V
Produktmaße: Ca. 184 * 144 * 78.5 mm	Betriebstemperatur: 10-40°C
Produktgewicht: Ca. 540 g	Betriebsfeuchtigkeit: 20~80%

FR Spécifications du Produit

Modèle: CB1	
Méthode de connexion: Connexion filaire	Courant de fonctionnement: ≤300mA
Dimensions du colis: Environ 231 * 241 * 120 mm	Tension de fonctionnement: 5V
Dimensions du produit: Environ 184 * 144 * 78.5 mm	Température d'utilisation: 10°C à 40°C
Poids du produit: Environ 540 g	Humidité d'utilisation: 20% à 80%

IT Specifiche Tecniche

Modello: CB1	
Metodo di connessione: Connessione cablata	Corrente di lavoro: ≤300mA
Dimensioni della confezione: Circa 231 * 241 * 120 mm	Tensione di funzionamento: 5V
Dimensioni della prodotto: Circa 184 * 144 * 78.5 mm	Temperatura di funzionamento: 10-40°C
Peso del prodotto: Circa 540 g	Umidità di funzionamento: 20~80%

ES Especificaciones

Modelo: CB1	
Método de conexión: Conexión por cable	Corriente de trabajo: ≤300mA
Dimensiones del paquete: Aprox. 231 * 241 * 120 mm	Voltaje de funcionamiento: 5V
Dimensiones del producto: Aprox. 184 * 144 * 78.5 mm	Temperatura de funcionamiento: 10-40°C
Peso del producto: Aprox. 540 g	Humedad de funcionamiento: 20~80%

RU Технические характеристики продукта

Модель: CB1	
Метод подключения: Проводное подключение	Рабочий ток: ≤300mA
Размеры упаковки: Около 231 * 241 * 120 мм	Рабочее напряжение: 5V
Размеры продукта: Около 184 * 144 * 78.5 мм	Допустимая температура: 10-40°C
Вес продукта: Около 540 г	Допустимая влажность: 20~80%

NL Productspecificaties

Model: CB1	
Verbindingsmethode: Bekabelde verbinding	Bedrijfsstroom: ≤300mA
Verpakkingsafmetingen: Ongeveer 231 * 241 * 120 mm	Bedrijfsspanning: 5V
Productafmetingen: Ongeveer 184 * 144 * 78.5 mm	Werktemperatuur: 10-40°C
Productgewicht: Ongeveer 540 g	Werkvochtigheid: 20~80%

PT Especificações Técnicas

Modelo: CB1	
Conexão: Conexão com fio	Corrente de trabalho: ≤300mA
Dimensões da Embalagem: Aprox. 231 * 241 * 120 mm	Tensão de operação: 5V
Dimensões do Produto: Aprox. 184 * 144 * 78.5 mm	Temperatura de Operação: 10-40°C
Peso do Produto: Aprox. 540 g	Umidade de Operação: 20~80%

PL Specyfikacje Produktu

Model: CB1	
Metoda połączenia: Połączenie przewodowe	Prąd roboczy: ≤300mA
Wymiary opakowania: Około 231 * 241 * 120 mm	Napięcie robocze: 5V
Wymiary produktu: Około 184 * 144 * 78.5 mm	Temperatura pracy: 10-40°C
Waga produktu: Około 540 g	Wilgotność robocza: 20~80%

TR Ürün Özellikleri

Model: CB1	
Bağlantı Yöntemi: Kablolu Bağlantı	Çalışma Akımı: ≤300mA
Paket Boyutları: Yaklaşık 231 * 241 * 120 mm	Çalışma Voltajı: 5V
Ürün Boyutları: Yaklaşık 184 * 144 * 78.5 mm	Çalışma Sıcaklığı: 10-40°C
Ürün Ağırlığı: Yaklaşık 540 g	Çalışma Nem Oranı: %20 ~ %80

HU Termék specifikációk

Modell: CB1	
Kapcsolási mód: Kábeles kapcsolat	Működési áram: ≤300mA
Csomag méretei: Kb. 231 * 241 * 120 mm	Működési feszültség: 5V
Termék méretei: Kb. 184 * 144 * 78.5 mm	Működési hőmérséklet: 10-40°C
Termék súlya: Kb. 540 g	Működési páratartalom: 20~80%

日本語 製品仕様

モデル: CB1	
接続方法: 有線接続	動作電流: ≤300mA
パッケージサイズ: 約 231 * 241 * 120 mm	動作電圧: 5V
製品サイズ: 約 184 * 144 * 78.5 mm	動作温度: 10-40°C
製品重量: 約 540 g	動作湿度: 20~80%

繁體中文 | **產品規格**

產品型號: CB1	
連接方式: 有線連接	工作電流: ≤300mA
包裝尺寸: 約 231 * 241 * 120 mm	工作電壓: 5V
本體尺寸: 約 184 * 144 * 78.5 mm	使用溫度: 10-40°C
本體重量: 約 540 克	使用濕度: 20~80%

簡體中文 | **产品规格**

产品型号: CB1	
连接方式: 有线连接	工作电流: ≤300mA
包装尺寸: 约 231 * 241 * 120 mm	工作电压: 5V
本体尺寸: 约 184 * 144 * 78.5 mm	使用温度: 10-40°C
本体重量: 约 540 克	使用湿度: 20~80%

深圳市莱仕达电子科技有限公司

型号: CB1 产品名称: 中控盒 客服热线: 400 600 3586 客服邮箱: lsd@e-pxn.com

客服QQ: 4006003586 官网: www.e-pxn.com.cn 地址: 深圳市宝安区西乡中熙ECO国际大厦1701-1706

Brand: PXN Model: CB1 Product Name: Control Box
Manufacturer: Shenzhen PXN Electronics Technology Co., Ltd Country of Origin: China
Web: www.e-pxn.com Support email: support@e-pxn.com
Manufacturer address: 1701-1706(01), Building 8, Zhongxi Xiangbinshan Garden,
Fenghuanggang Community, Xixiang Street, Baoan District, Shenzhen, China



EUREP GmbH
Unterlettenweg 1a
85051 Ingolstadt Germany
+49 841 8869 7744
eurep@eurep-gmbh.com



UK001732867424878mGIM

We simply act as UK representative for cross-border sellers, and are not manufacturers/importers/distributors for the product, nor involved in the manufacture/import/sale of the product. Therefore, we are not responsible for any after-sales services related to the product. In case of any product quality or infringement issues, the manufacturer/importer/seller shall be solely held responsible.

EVATOST CONSULTING LTD
Office 101 32 Threadneedle Street,
London, United Kingdom, EC2R 8AY
contact@evatost.com

"PXN" is a registered trademark of ShenZhen PXN Electronics Technology Co., Ltd

FCC Compliance Statement:

This device complies with Part 15 of the FCC Rules. Operation is subject to the following two conditions:

1. This device may not cause harmful interference, and
2. This device must accept any interference received, including interference that may cause undesired operation.

Note: This equipment has been tested and found to comply with the limits for a Class B digital device, pursuant to Part 15 of the FCC Rules. These limits are designed to provide reasonable protection against harmful interference in a residential installation.

This equipment generates, uses and can radiate radio frequency energy and, if not installed and used in accordance with the instructions, may cause harmful interference to radio communications.



Points de collecte sur www.quefairedemesdechets.fr
Privilégiez la réparation ou le don de votre appareil !

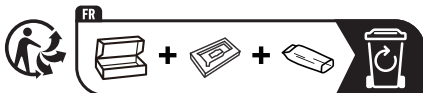

MADE IN CHINA